



# FORESTRY KIT KIT de FORESTERIE

- UNDERCARRIAGE
- UPPER FRAME
- CAB OPTIONS
- BOOM OPTIONS
- MISC. OPTIONS
- CHÂSSIS
- CHÂSSIS SUPÉRIEUR
- OPTIONS CABINE
- OPTIONS BOOM
- DIVERS OPTIONS



# FORESTRY KIT | KIT de FORESTERIE | OPTION

**HYDRAULIC PIPE UPGRADE**



**MAIN BOOM HD LIGH GUARD**



**NOSE CONE ATTACHMENT**



**HD Canopy**



**HD BRUSH GUARD  
(front right,  
3/16" plate design)**



**Lexan Front Windshield  
(1/2" clamped style)**



**Cylinder Protection**



**Lexan left upgrade  
(door bottom + rear)**







**Complete Hood Cover**



**HD Doors & Panels  
(+ rad mesh grill on hinges)**



**Camera Guard**



**Catwalk with Toolbox  
(both sides)**



**HD Swivel  
Protection Plate**

**HD Traction Covers**

**HD Underplating**



**Boom Rubber Guard**



**Hydraulic tank  
fill cap**



**Fuel Cap Protector**





FORESTRY KIT | KIT de FORESTERIE | MISC.



Raised Cab

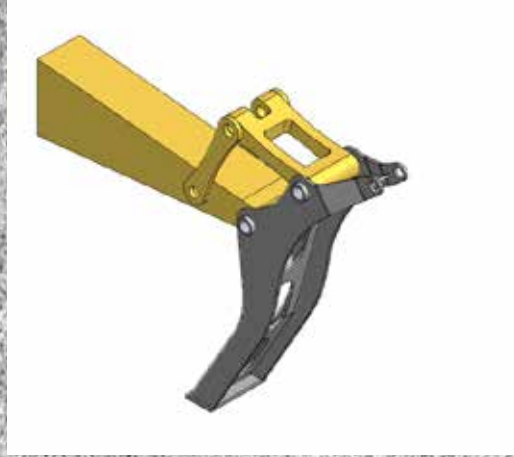

Live Heel Boom



Windshield Grill

# MORE INFO

# PLUS INFO



512, Avenue des Pionniers  
C.P. 2532,  
Balmoral (NB),  
Canada E8E 2W7

tel : +1 (1) 506 826-9818  
fax : +1 (1) 506 826-9303  
eMail: [alfab@alfabrication.com](mailto:alfab@alfabrication.com)  
web: [www.alfabrication.com](http://www.alfabrication.com)

## **A.L.P.A.** **EQUIPMENT LTD**

**Serving Atlantic Canada, Gaspésie and the Lower-Saint-Laurence of Quebec**  
**Au service des provinces Atlantique, de la Gaspésie et du Bas-Saint-Laurent Québec**

Balmoral, NB  
P.O. Box 2532  
258 Drapeau St.  
Balmoral, N.B.  
E8E 2W7

Fredericton, NB  
P.O. Box 3067, Site B  
289 HWY 105, Maugerville  
Fredericton, N.B.  
E3A 5G8

Edmundston, NB  
P.O. Box 93  
800 Canada St  
Edmundston, N.B.  
E3V 3K7

Truro, Nova Scotia  
69 Hub Centre Drive  
Upper Onslow, NS  
B6L 0C8

Tel: 506 826-2717

Tel: 506 452-9818

Tel: 506 735-4144

Tel: (902) 897-2717

[www.alpaequipment.com](http://www.alpaequipment.com)